

Panasonic

Color CCTV Camera Operating Instructions

Model No. **WV-CP474H**

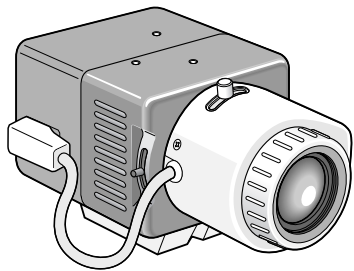

(Lens: Option)

Before attempting to connect or operate this product,
please read these instructions carefully and save this manual for future use.

N1002-0 3TR001320AAA Printed in Japan
N 19

For U.S.A

NOTE: This equipment has been tested and found to comply with the limits for a Class A digital device, pursuant to Part 15 of the FCC Rules. These limits are designed to provide reasonable protection against harmful interference when the equipment is operated in a commercial environment. This equipment generates, uses, and can radiate radio frequency energy and, if not installed and used in accordance with the instruction manual, may cause harmful interference to radio communications. Operation of this equipment in a residential area is likely to cause harmful interference in which case the user will be required to correct the interference at his own expense.

FCC Caution: To assure continued compliance, (example - use only shielded interface cables when connecting to computer or peripheral devices). Any changes or modifications not expressly approved by the party responsible for compliance could void the user's authority to operate this equipment.

The serial number of this product may be found on the top of the unit. You should note the serial number of this unit in the space provided and retain this instruction as a permanent record of your purchase to aid identification in the event of theft.

Model No. WV-CP474H

Serial No. _____



CAUTION: TO REDUCE THE RISK OF ELECTRIC SHOCK,
DO NOT REMOVE COVER (OR BACK).
NO USER-SERVICEABLE PARTS INSIDE. REFER SERVICING TO QUALIFIED SERVICE PERSONNEL.

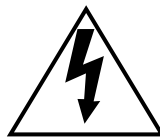

SA 1965

The lightning flash with arrowhead symbol, within an equilateral triangle, is intended to alert the user to the presence of uninsulated "dangerous voltage" within the product's enclosure that may be of sufficient magnitude to constitute a risk of electric shock to persons.



SA 1966

The exclamation point within an equilateral triangle is intended to alert the user to the presence of important operating and maintenance (servicing) instructions in the literature accompanying the appliance.

WARNING: To prevent fire or electric shock hazard, do not expose this appliance to rain or moisture. The apparatus shall not be exposed to dripping or splashing and that no objects filled with liquids, such as vases, shall be placed on the apparatus.

PREFACE

Panasonic's WV-CP474H series color digital camera introduces a new level of high picture quality and high resolution through the use of a 1/3-inch interline transfer CCD image sensor having 771 horizontal pixels (picture elements), and digital signal processing LSIs. This model offers cutting-edge technology for advanced video surveillance.

PRECAUTIONS

- Do not attempt to disassemble the camera.**
To prevent electric shock, do not remove screws or covers. There are no user-serviceable parts inside. Ask a qualified service personnel for servicing.
- Handle the camera with care.**
Do not abuse the camera. Avoid striking, shaking, etc. The camera could be damaged by improper handling or storage.
- The installation should be made by qualified service personnel or system installers.**
- Do not use strong or abrasive detergents when cleaning the camera body.**
Use a dry cloth to clean the camera when dirty. When the dirt is hard to remove, use a mild detergent and wipe gently. Then wipe off the remaining detergent with a dry cloth.
- Clean the CCD faceplate with care.**
Do not clean the CCD with strong or abrasive detergents. Use lens tissue or a cotton tipped applicator and ethanol.
- Never face the camera towards the sun.**
Do not aim the camera at bright objects. Whether the camera is in use or not, never aim it at the sun or other extremely bright objects. Otherwise, blooming or smear may be caused.
- Do not operate the camera beyond the specified temperature, humidity or power source ratings.**
Use the camera at temperatures within -10°C to $+50^{\circ}\text{C}$ (14°F - 122°F), and humidity below 90%. The input power source is 24 V.
- Avoid do connections during a lightning storm.**
Otherwise, electric shock may be caused.

Caution:

To prevent fire or electric shock hazard, use a UL listed cable (VW-1, style 1007) for the AC 24 V Input Cable.

FEATURES

- The following functions are built in.
 - Auto Light Control (ALC)/Electronic Light Control (ELC)
 - The SUPER-D II function eliminates interference by strong background lighting which makes the camera picture dark, such as a spotlight. Dynamic range of 46 dB.
 - Internal Line-locked Multiplex Vertical (VD2) Sync.
 - Auto/Manual White Balance Function
 - Electronic Shutter Function
- Signal-to-noise ratio of 50 dB (Equivalent to AGC Off)
- Minimum Illumination of 0.8 lx (0.08 foot-candle) at color mode, 0.1 lx (0.01 foot-candle) at black and white mode with F1.4 lens.
- 480 lines of horizontal resolution
- High quality picture:
 - 2H type vertical enhancer for greater picture sharpness
 - Chroma averaging circuit for better color signal-to-noise ratio
 - Minimum of aliasing on fine objects
 - Expanded dynamic range by use of knee circuit
 - Highlight aperture correction for greater picture detail of bright objects
- Ability to shoot indoor scenes with fixed iris lens by use of Electronic Light Control (ELC) function.
- Selectable electronic sensitivity enhancing modes including AUTO, MANUAL and OFF
- Built-in Digital Motion Detector
- Auto black-and-white mode enables the camera to switch between color and black-and-white picture in response to light input.

MAJOR OPERATING CONTROLS AND THEIR FUNCTIONS

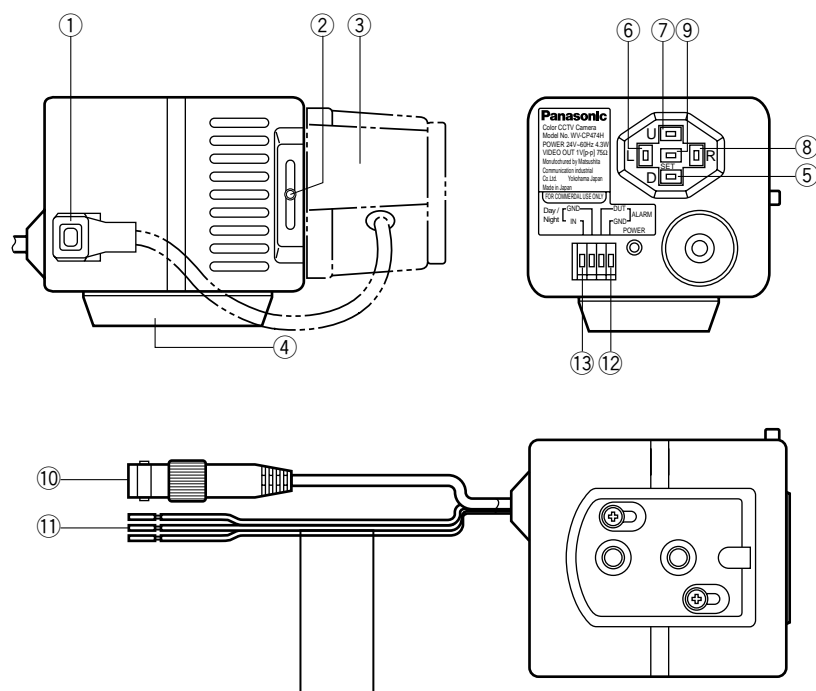

Slide the panel to the left until it locks.

- Auto Iris Lens Connector**
Connects the auto iris lens with a 4-pin male connector supplied as a standard accessory (Part No. YFE4191J100).
- Flange-back Adjusting Ring & Screw**
Adjusts the back focal length and picture focus.
- Lens (Option)**
- Camera Mounting Screw Hole**
Mounts the camera onto a mounting bracket.
- Down Button (D)**
Moves the cursor downward and selects items in the CAM SET UP menu.
- Left Button (L)**
Moves the cursor to the left, selects the mode and adjusts some levels.
- Up Button (U)**
Moves the cursor upward and selects items in the CAM SET UP menu.
- Right Button (R)**
Moves the cursor to the right, selects the mode and adjusts some levels.
- Set Button (SET)**
Activates an item selected in the CAM SET UP menu.
- Video Output Cable with BNC Connector**
Connects the VIDEO IN connector of the monitor.
- Power Cable**
- Alarm Output Terminal (ALARM OUT/GND)**
Connects to the alarm input connector (terminal) of an external device. When the camera detects motion, the alarm output signal is supplied to the connected external device (Open collector output: 16 V DC, 100 mA max).
- Day/Night Input Terminal (DAY/NIGHT IN/GND)**
This terminal is used for connecting the camera to an external day/night detecting sensor.

Cautions:

1. CONNECT THIS TO 24 V AC CLASS 2 POWER SUPPLY ONLY. Be sure to connect the grounding lead to the GND terminal.
2. To prevent fire or electric shock hazard, use a UL listed cable (VW-1, style 1007) for the Input Terminal.
3. The connections should comply with National Electrical Code (NEC).

CONNECTIONS**Connections****Precaution:**

The following connections should be made by qualified service personnel or system installers in accordance with NEC 725-51.

Note: For the WV-CP474E Colour CCTV Camera, do not use a transformer larger than 10 VA.

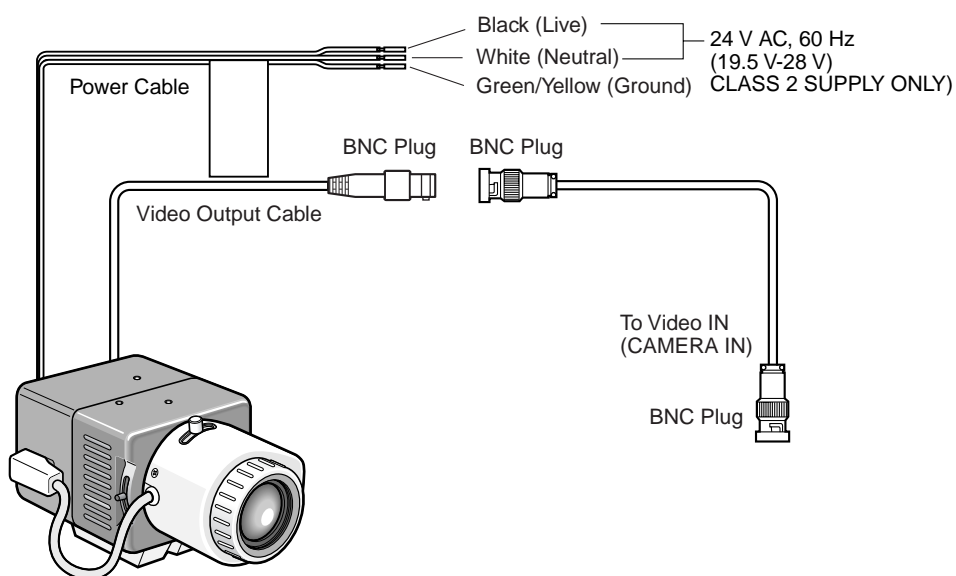
**Power supply connection**

Recommended wire gauge sizes for 24 V AC line.

| Copper wire size (AWG) | | #24 (0.22 mm ²) | #22 (0.33 mm ²) | #20 (0.52 mm ²) | #18 (0.83 mm ²) |
|---------------------------|------|--------------------------------|--------------------------------|--------------------------------|--------------------------------|
| Length of cable (Approx.) | (m) | 20 | 30 | 45 | 75 |
| | (ft) | 65 | 100 | 160 | 260 |

Cautions:

1. Shrinking the cable-entry seal is a one-time procedure. Do not shrink the cable-entry seal until it has been ascertained that the unit is functioning.
2. CONNECT THIS TO 24 V AC CLASS 2 POWER SUPPLY ONLY. Be sure to connect the grounding lead to the GND terminal.
3. To prevent fire or electric shock hazard, use a UL listed cable (VW-1, style 1007) for the Input Terminal.
4. The connections should comply with National electrical Code (NEC).

Alarm Connections

1. Connect an external sensor to the DAY/NIGHT terminal.
2. Connect an external device such as a buzzer or lamp to the ALARM terminal.
 - The alarm output terminal is an open collector terminal with a capacity of 16 V DC, 100 mA or less.
OFF: Open contact
ON: 100 mA or less
 - Color/black-and-white input terminal with a capacity of 5 V DC pull-up input, 0.2 mA or more.
OFF: Open contact
ON: Closed contact

Notes:

- Use a relay unit if the voltage or current of the connected device exceeds the ratings.
- To validate the Day/Night function, set BW mode to EXT on the special menu.

MOUNTING LENS/FOCUS ADJUSTMENT**Installation of Auto Iris Lens Connector**

Install the lens connector (YFE4191J100) when using a video drive ALC lens.

- (1) Cut the iris control cable at the edge of the lens connector to remove the existing lens connector and then remove the outer cable cover as shown in the figure below. The pin assignment of the lens connector is as follows:
 - Pin 1: Power source; +9 V DC, 50 mA max.
 - Pin 2: Not used
 - Pin 3: Video signal; 0.7 V[p-p]/40 k Ω
 - Pin 4: Shield, ground

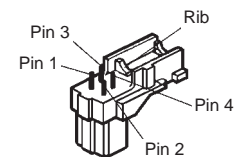

- (2) Solder the lens cable to the pins of the supplied connector.

Caution for Mounting the Lens

Follow the indication shown in the figure for the protrusion between a lens and the camera body. This camera wears mount for use with the CS-mount lens at the factory shipment. Use the supplied C-mount adapter when using the C-mount lens.

The lens less than 450 g (0.99 lbs) can be mounted on the camera. If the lens is heavier, both the lens and camera should be secured by the supporter.

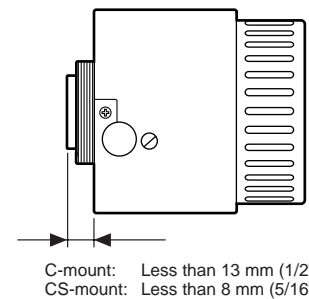
**Mounting the Lens**

Note: Before you mount the lens, loosen the screw on the side of the camera, and rotate the ring clockwise until it stops. If the ring is not at the end, the inner glass or CCD image sensor may be damaged.

1. Attach the supplied C-mount adapter when using a C-mount lens.
2. Jump to step 3 if the lens has focus adjusting mechanism. Loosen the flange-back screw, and rotate the adjusting ring down until it stops on the side of the camera.
3. Mount the lens.
4. Connect the lens cable to the auto iris connector on the side of the camera.

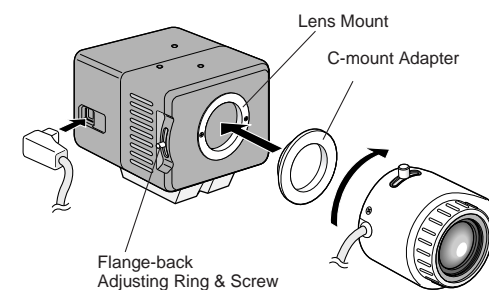
**Flange-back Adjustment**

The adjustment is required only when a lens without focus-adjusting mechanism is mounted, or when a lens with adjusting mechanism is mounted and focus that is more accurate is needed.

1. Loosen the flange-back fixing screw on the flange-back adjusting ring.
2. Turn the flange-back adjusting ring to obtain a focused point while watching the monitor screen.
3. Tighten the flange-back fixing screw on the flange-back adjusting ring.

Caution: Tightening the screw by force will cause damage to the screw or deviation of focus.

Note: The object may be out of focus when using a source of near-infrared light than using the visible light.

INSTALLATION OF CAMERA**Mounting from the Top**

Remove the mount adapter from the bottom of the camera by removing the two fixing screws. Attach the mount adapter to the top as shown in the figure, then mount the camera on the mounting bracket.

Cation:

Be sure to use two original fixing screws for the mount adapter. Longer screws may damage the inner components. Or shorter screws may cause the camera drop.

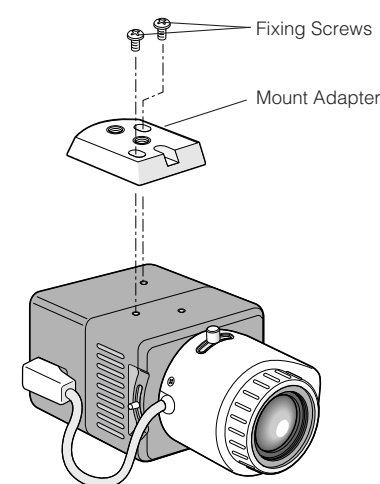

SETUP

1. CAMERA SETUP MENU

This camera utilizes an on-screen user setup menu.

• Opening the Setup Menu

Press and hold down **SET** for 2 seconds or more.

The CAM SET UP menu appears on the monitor as shown in the figure. Check the current settings on the menu.

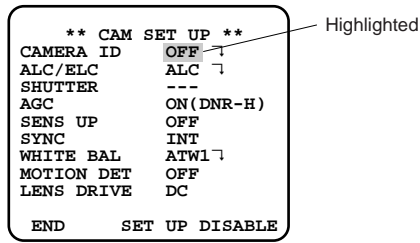

Refer to the following sections for a detailed description of menu items. If you decide not to make any changes after checking the current settings, move the cursor to END in the bottom line, and press **SET** to close the setup menu.

Note: If no button is pressed for 6 minutes while any of the setup menu is being displayed on the monitor screen, it is automatically closed and the mode returns to the normal camera picture.

2. SETUP OPERATION

This camera utilizes an on-screen user setup menu (CAM SET UP). To set items on the CAM SET UP menu, use the following buttons on the side panel.

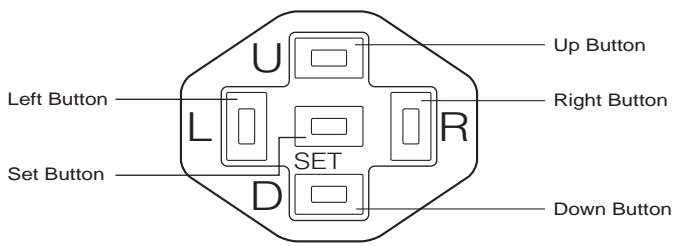

- Up Button: Moves the cursor upwards. Use this button to select an item or adjust the parameters.
- Down Button: Moves the cursor downwards. Use this button to select an item or adjust the parameters.
- Right Button: Moves the cursor to the right. Use this button to select or adjust the parameters of the selected item. The parameter changes each time this button is pressed.
- Left Button: Moves the cursor to the left. Use this button to select or adjust the parameters of the selected item. The parameter changes each time this button is pressed.
- Set Button: Executes selections and displays a submenu for an item with the ↓ mark.

- To reset the parameter to the factory default setting, move the cursor to the parameter to be reset and press **L** and **R** simultaneously.
- To return to the previous menu or page, move the cursor to RET and press **SET**.
- To close the setup menu, move the cursor to END and press **SET**.

• All Reset Operation

All reset allows you to reset all setup menu items to the factory default settings if you are unsure about the correct settings. Proceed as follows:

- (1) Make sure that the CAM SET UP menu is not displayed (a camera picture is displayed).
- (2) While pressing both **L** and **R**, press **SET** for a few seconds. The message ALL RESET momentarily appears on the monitor screen. This resets all adjustments and parameters to the factory default settings.

• Editing the CAM SET UP Menu

Important Notice:

When SET UP DISABLE appears in the bottom line of the CAM SET UP menu, you cannot change the currently active settings. This is to prevent accidental changing of the settings.

To edit the CAM SET UP menu (change settings), press **U** and **D** or **L** and **R** to move the cursor to SET UP DISABLE in the bottom line.

Press **SET**. SET UP DISABLE changes to SET UP ENABLE. Move the cursor to END, then to the item(s) you want to change.

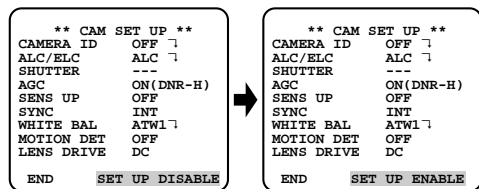

Important Notice:

When the setup menu is closed after changing the parameters in the menu, the new values are stored in the EEPROM (Electrically Erasable and Programmable Read-Only Memory). These values remain valid until new values are stored, even if the power of the camera is off.

SETTING PROCEDURES

1. Camera Identification (CAMERA ID) Setting

You can use the camera identification (CAMERA ID) to assign a name to the camera. The camera ID consists of up to 16 alphanumeric characters. The camera ID display can be switched on or off on the monitor screen.

To edit the CAMERA ID

1. Move the cursor to CAMERA ID. The factory default setting is OFF.
2. Press **SET**. The CAMERA ID menu appears. The cursor on the letter "0" is highlighted.
3. Move the cursor to the character you want to edit by pressing **L/R/U/D**.
4. After selecting the character, press **SET**. The selected character appears in the editing area. (The pointer in the editing area moves to the right automatically at this moment.)
5. Repeat the steps above until all characters are edited.

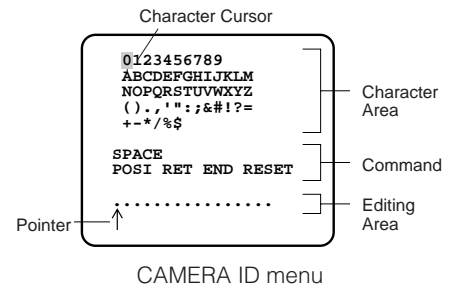

To enter a blank space in the CAMERA ID

Move the cursor to SPACE and press **SET**.

To replace a specific character in the CAMERA ID

1. Move the cursor to the editing area by pressing **D**.
2. Move the pointer to the character to be replaced by pressing **L** or **R**. Then move the cursor to the character area and select a new character.
3. Press **SET** to determine the CAMERA ID.

To clear all characters in the editing area

Move the cursor to RESET and press **SET**. All characters in the editing area disappear.

To determine the display position of the CAMERA ID

1. Move the cursor to POSI, and press **SET**. The display in the figure appears and the CAMERA ID is highlighted.
2. Move the CAMERA ID to the desired position by pressing **L/R/U/D**.
3. Press **SET** to fix the position of the CAMERA ID. The mode returns to the previous CAMERA ID menu.

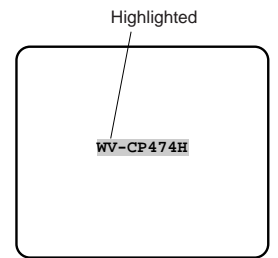

Notes:

- The CAMERA ID stops at the edges of the monitor screen.
- The CAMERA ID moves faster if any of **L/R/U/D** is kept pressed for a second or more.

2. Light Control Setting (ALC/ELC)

You can select the mode for adjusting the lens iris.

ALC: If you use the auto iris lens, select this parameter.

ELC: If you use a fixed or manual iris lens, select this parameter.

The factory default setting is ALC.

1. Move the cursor to ALC/ELC.
2. Select ALC or ELC.

Cautions:

1. Under bright lighting conditions such as outdoors, use an ALC type lens because the ELC control range is not wide enough under these conditions.
2. Use an ALC type lens if the following phenomena occur:
 - Strong smear and/or blooming on highlight objects such as spotlight or sunlight from windows.
 - Noticeable flicker in the picture and/or color rendition variations.
3. If ELC is selected, SUPER-D2 and SHUTTER are not available and white balance mode is automatically set to ATW1 or ATW2 previously set.
4. If ELC is selected for ALC/ELC and used with the fixed iris lens in, the focal depth becomes shallower than with the ALC type lens. Therefore, the range of focus-to-object distance becomes narrower.

2-1. ALC Mode with SUPER-D2 ON

Super Dynamic II Function (SUPER-D2)

The important object in a scene is usually placed in the center of the monitor screen. In the SUPER-D2 mode, more photometric weight is given to the center of the screen (where the important object is located) than to the edge of the screen (where a bright backlight would most likely be located). You can use the SUPER-D II function if you select ALC. It eliminates interference by strong background lighting which makes the camera picture dark, such as a spotlight.

1. Select ALC, and press **SET**. The ALC CONT menu appears.
2. Move the cursor to SUPER-D2 and select ON.

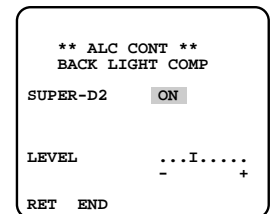

3. If you want to adjust the video output level, move the "I" cursor for LEVEL. Adjust to the desired level by pressing **L** or **R**.

SETTING PROCEDURES

2-2. ALC Mode with SUPER-D2 OFF and ELC Mode

Note: If ELC is selected, set MASK SET according to this procedure.

1. Move the cursor to SUPER-D2 and select OFF. (When you select ELC, SUPER-D2 is not available.) The MASK SET appears on the menu.

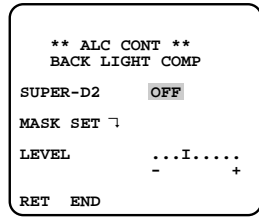

2. Move the cursor to MASK SET and press **SET**. The 48 mask areas appear on the monitor screen. The cursor is blinking in the upper left corner of the screen.

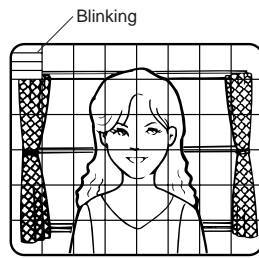

3. Move the cursor to the area where backlight is bright and press **SET** to mask that area. The mask turns to white. (When the cursor is moved on an area that has already been masked, the mask and cursor start blinking.)

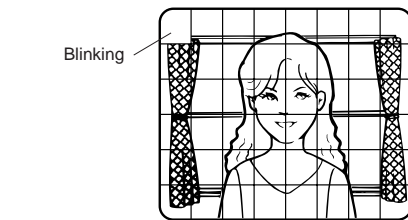

4. Repeat step 3 to mask the desired area. To cancel masking, move the cursor to that area and press **SET**.

5. After masking is completed, press **SET** for 2 seconds or more. The ALC CONT menu appears.

6. If you want to change the video output level (picture contrast), move the "I" cursor for LEVEL and adjust the level.

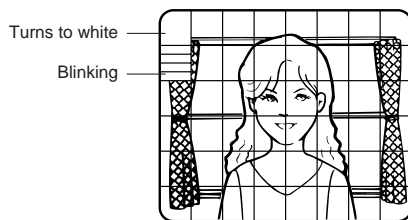

Note: If ON is selected for SUPER-D2, a shadow (black line) may appear at the boundary between the bright and the dim scene. This is a natural phenomenon and does not indicate trouble.

3. Shutter Speed Setting (SHUTTER)

Note: When ELC is selected for ALC/ELC on the CAM SET UP menu or ON is selected for SUPER-D2 on the ALC CONT menu, this item is not available.

To select electronic shutter speed, select OFF for SUPER-D2 in the ALC CONT menu.

Move the cursor to SHUTTER and select the electronic shutter speed.

The preset values for SHUTTER (electronic shutter speed) change by pressing **L** or **R** as follows:

The factory default setting is ---.

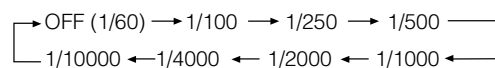

4. Gain Control Setting (AGC ON (DNR-H, DNR-L)/OFF)

AGC (Automatic Gain Control) automatically controls the gain (an image brightness level). Move the cursor to AGC and select automatic level adjustment ON (DNR-H), ON (DNR-L), or OFF. The factory default setting is ON (DNR-H).

ON (DNR-H): This setting raises the gain and brightens the image under low light conditions.

ON (DNR-L): This setting reduces an afterimage sometimes caused by a moving object when ON (DNR-H) is activated.

OFF: This setting does not control the gain.

Notes:

- When ON (DNR-L) is selected, noise can slightly increase than ON (DNR-H).
- DNR-H and DNR-L do not appear on the system status display of the connected equipment.

5. Electronic Sensitivity Enhancement (SENS UP)

There are two modes for SENS UP.

AUTO: If you select X10 AUTO, for example, the sensitivity is automatically raised to X10 max. When AUTO is selected, AGC is automatically set to ON.

FIX: If you select X32 FIX, for example, the sensitivity is raised to just X32. The factory default setting is OFF.

Move the cursor to SENS UP and select the parameter for electronic sensitivity enhancement.

The preset values for SENS UP (electronic sensitivity enhancement) change by pressing **L** or **R** as shown right:

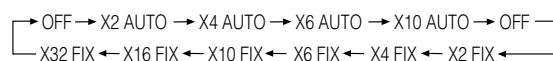

Notes:

- When ON is selected for SUPER-D2 in the ALC CONT menu, FIX is not available for this item.
- When you select AUTO for SENS UP and ON for SUPER-D2, the SENS UP function has priority so that the SUPER-D II function is not activated automatically.
- While the SENS UP function is selected, noise, spots or a whitish phenomenon may appear in the picture when the sensitivity of the camera is increased. This is a normal phenomenon.

6. Synchronization Setting (SYNC)

You can select internal sync (INT) mode, line-lock (LL) mode or the VD2 signal (multiplexed vertical drive signal) mode.

1. Move the cursor to SYNC and select LL or INT.

The factory default setting is INT.

2. Press **SET**.

If LL is selected, the SYNC menu appears. (If VD2 or INT is not selected, the synchronization mode automatically set and the menu does not appear.)

Important Notices:

1. The priority for the sync modes is as follows:

- Multiplexed Vertical Drive (VD2) (Highest priority)
- Line-lock (LL)
- Internal Sync (INT) (Lowest priority)

2. The line-lock mode has a submenu for line-lock vertical phase adjustment. If the camera installation is relocated, check the vertical phase adjustment again since the AC line phase may be different.

Whenever the multiplexed vertical drive pulse (VD2) is supplied to the camera from external equipment such as a matrix switcher, the camera sync mode is automatically switched to the VD2 mode.

6-1. Line-lock Sync Mode (LL)

1. Move the cursor to SYNC and select LL.

Note: The settings in this menu can be made only when the multiplexed vertical drive signal (VD2) is not supplied to the camera.

2. After confirming that the cursor is on LL, press **SET**. The vertical phase adjustment menu appears on the monitor screen.

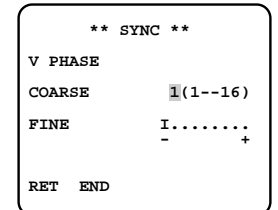

3. Supply the video output signal of the camera to be adjusted and the reference camera video output signal to a dual-trace oscilloscope.

4. Set the oscilloscope to the vertical rate and expand the vertical sync portion on the oscilloscope.

5. Move the cursor to COARSE. The cursor is highlighted.

6. Press **L** or **R** to match the vertical phase for both video output signals as closely as possible. (COARSE adjustment can be incremented in 16 steps by 22.5 degrees by pressing **L** or **R**.)

Note: After the sixteenth step, the adjustment returns to the first step.

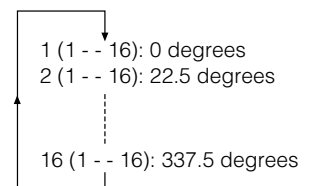

7. Move the cursor to FINE.

8. Press **L** or **R** to match the vertical phase for both video output signals as closely as possible.

(FINE adjustment can be made by up to 22.5 degrees by pressing **L** or **R**.)

Notes:

- When the "I" cursor reaches the "+" end, it jumps back to "-". At the same time, COARSE is incremented by one step to enable a continuous adjustment. The reverse takes place when the "I" cursor reaches the "-" end.
- When **L** or **R** is kept pressed for a second or more, the "I" cursor moves faster.
- To reset COARSE and FINE to the values preset at the factory, press **L** and **R** simultaneously. COARSE and FINE adjustments are preset at the factory to zero-crossing of the AC line phase.
- If the AC line contains noise (spike noise, etc.), the stability of the vertical phase of the camera video output signal may be disturbed.

7. White Balance Setting (WHITE BAL)

7-1. Auto-Tracing White Balance Mode (ATW)

You can select one of three modes for white balance adjustment as follows:

The factory default setting is ATW1.

• ATW1 (Auto-Tracing White Balance 1)

Move the cursor to WHITE BAL and select ATW1.

In this mode, the color temperature is monitored continuously and thereby white balance is automatically set. The color temperature range for the proper white balance is approximately 2 600 - 6 000K. Proper white balance may not be obtained under the following conditions:

- The color temperature is out of the 2 600 - 6 000K range.
- When the scene contains mostly high color temperature objects, such as a blue sky or sunset.
- When the scene is dim.

In these cases, select the AWC mode.

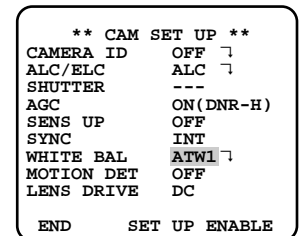

• ATW2 (Auto-Tracing White Balance 2)

Auto-tracing white balance in sodium lamp mode (ATW2)

When you select ATW2 for sodium lamp, white balance is automatically set (no operation needed).

Note: ATW1 and ATW2 do not appear for WHITE BAL on the system controller setup menu.

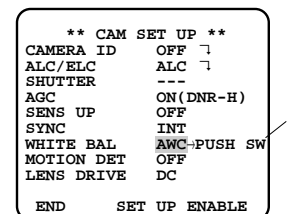

• Automatic White Balance Control Mode (AWC)

In this mode, accurate white balance is obtained within a color temperature range of approximately 2 300-10 000K.

1. Move the cursor to WHITE BAL and select AWC → PUSH SW.

2. Press **SET** to start the white balance setup. The PUSH SW is highlighted to indicate that the white balance is being set.

3. When the white balance setting is completed, the PUSH SW returns to normal display.

Note: If white balance is not set, the PUSH SW is being highlighted.

- When you want to adjust the white balance manually, press **R** to select AWC and press **SET**. The AWC menu appears on the monitor screen. (When ATW is selected, pressing **SET** displays the ATW menu.)

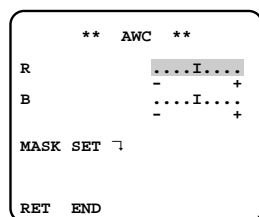

Manual Fine Adjustment for AWC (ATW)

You can set the white balance items manually.

- To set MASK SET, proceed as described in steps 2 to 4 of "ALC mode with SUPER-D2 OFF and ELC mode".
- Move the cursor to R.
- Press **L** or **R** to obtain the optimum amount of red gain.
- Move the cursor to B.
- Press **L** or **R** to obtain the optimum amount of blue gain.

Note: When you need to set MASK SET, re-adjust to obtain the optimum amount of red and blue gain.

8. Motion Detector Setting (MOTION DET)

The motion detector detects the moving objects in the scene by monitoring changes in brightness level. You can select the level of sensitivity for motion detection.

When this camera is connected to a compatible intelligent CCTV system, the camera transmits an alarm signal by multiplexing it with the video signal.

- Move the cursor to MOTION DET and select ON. The factory default setting is OFF.
- Press **SET**. The MOTION DETECT menu appears on the monitor screen.

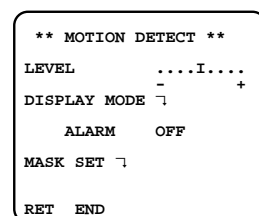

- Move the cursor to MASK SET and press **SET**. MASK SET lets you set 48 mask areas. To set MASK SET, proceed as described in steps 2 to 4 of "ALC mode with SUPER-D2 OFF and ELC mode".
- Move the cursor to ALARM and select ON or OFF to set the alarm for DISPLAY MODE. **Note:** When using the WV-RM70, WV-CU550 series, WV-CU161 or WV-CU360 controller with this model, select OFF for ALARM.
- Move the cursor to DISPLAY MODE and press **SET** to see the current setting. The masks that detect the brightness changes start blinking.
- To raise detection sensitivity, press **SET** to return to the MOTION DETECT menu.
- To obtain the optimum detection level, move the "I" cursor to adjust the level.
- Repeat the procedures above to obtain a satisfactory setting.

Notes:

- When the camera is not used in a Panasonic Intelligent CCTV System, select OFF. Otherwise, video equipment may malfunction because of the alarm signal misinterpretation for a time code signal.
- The motion detector may malfunction when the lightning equipment continuously turns on and off, or when ELC mode is selected for ALC/ELC.
- Set MASK SET over the areas where leaves or curtains etc. are swaying.
- Adjust the detection level on the menu to prevent misinterpretation under low light conditions with noise.
- It takes about 0.2 seconds for the alarm signal to reach the VCR's alarm terminal after the camera detects the moving object.
- The motion detector is not specifically intended to prevent theft or fire.

9. Lens Drive Signal Selection (LENS DRIVE)

This item is used to select the type of auto iris lens drive signal to be supplied to the lens from the auto iris lens connector.

- Move the cursor to LENS DRIVE. The factory default setting is DC.
- Select DC if you are using the auto iris lens that requires a DC drive signal. Select VIDEO if you are using the auto iris lens that requires a video drive signal.

10. Special Menu

This menu lets you adjust and set up the video signal of the camera to meet your requirements.

Move the cursor to END in the bottom line of the CAM SET UP menu and press **L** and **R** simultaneously (holding down **L** and press **R**) for 2 seconds or more. The SPECIAL menu appears on the monitor screen.

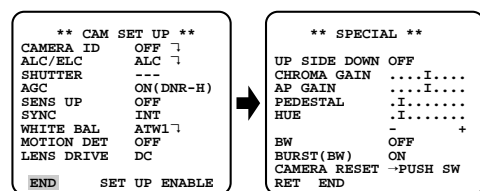

10-1. Camera Picture Upside Down Positioning (UP SIDE DOWN)

- Move the cursor to UP SIDE DOWN.
- Select ON when you want to turn the picture upside down.

10-2. Chroma Level Setting (CHROMA GAIN)

- Move the cursor to CHROMA GAIN.
- While observing the vectorscope or color video monitor, move the "I" cursor to adjust the chroma level.

10-3. Aperture Gain Setting (AP GAIN)

- Move the cursor to AP GAIN.
- While observing the waveform monitor or color video monitor, move the "I" cursor to adjust the aperture gain level.

10-4. Pedestal Level Setting (PEDESTAL)

- Move the cursor to PEDESTAL.
- While observing the waveform monitor or color video monitor, move the "I" cursor to adjust the pedestal level (black level).

10-5. Chroma Phase (Hue) Setting (HUE)

- Move the cursor to HUE.
- While observing the vectorscope or color video monitor, move the "I" cursor to adjust the hue (chroma phase) level.

10-6 BW

This function lets you automatically switch from color to black-and-white pictures in low light conditions such as at night.

- Move the cursor to BW.
- Select AUTO1, AUTO2, EXT, ON or OFF using **L** or **R**.

AUTO1: The camera selects black and white mode if the picture is dark, or color mode if the picture is bright enough.

AUTO2: Applying AUTO1 may cause malfunction when using a source of near-infrared light at night because the illuminance changes significantly when switching between a color picture and a black-and-white picture. This can be prevented by using the AUTO2 setting to detect the type of light source.

Note: Because the type of light source is detected based on information received from the CCD image pickup element, an object that is constantly moving or has the same color as its background may not always be properly recognized. When choosing the AUTO2 mode, make sure to use a light source having a wavelength of 800 nm or more.

EXT: Color picture reverts to black-and-white picture when an external day/night switching signal is received (refer to alarm connections).

ON: Black-and-white mode enabled.

OFF: Color mode enabled.

The factory default setting is OFF.

- Select AUTO1 or AUTO2 using **L** or **R**.

- Press **SET**.

The AUTO1 or AUTO2 menu appears on the monitor screen.

- Move the cursor to LEVEL and select the illuminance level using **L** or **R**.

LOW: Color picture switches to black-and-white picture at approx. 1 lx with F1.4 lens.

HIGH: Color picture switches to black-and-white picture at approx. 5 lx with F1.4 lens.

The factory default setting is HIGH.

- Move the cursor to DURATION TIME to set the switching time using **L** or **R**.

The following switching times are available:

10s--30s--60s--300s
(S) (L)

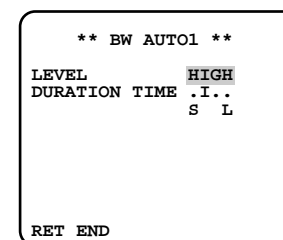

10-7 BURST (BW)

- Move the cursor to BURST (BW).
- Select ON or OFF using **L** or **R**.

ON: The burst signal is supplied along with the black-and-white composite video signal.

OFF: The burst signal is not output.

The factory default setting is ON.

Notes:

- We recommend that you usually select ON.
- When the camera is used to synchronize the system for external sync, select ON to prevent a malfunction.

To reset to the factory settings (CAMERA RESET)

- Move the cursor to CAMERA RESET. The PUSH SW is highlighted.
- While holding down **L** and **R**, press **SET** for 2 seconds or more. The camera is reset to the factory settings.

SPECIFICATIONS

| | |
|-------------------------------------|---|
| Pick-up Device: | 771 (H) x 492 (V) pixels, Interline Transfer CCD |
| Scanning Area: | 4.8 (H) x 3.6 (V) mm (Equivalent to scanning area of 1/3" pick-up tube) |
| Scanning: | 525 lines/60 fields/30 frames |
| Horizontal: | 15.734 kHz |
| Vertical: | 59.94 Hz |
| Synchronization: | Internal, Line-locked or Multiplexed Vertical Drive (VD2) selectable |
| Video Output: | 1.0 V[p-p] NTSC composite 75 Ω /BNC connector |
| Horizontal Resolution: | 480 lines (C/L), 570 lines (B/W) |
| Signal-to-Noise Ratio: | 50 dB (Equivalent to AGC Off, weight On) |
| Dynamic Range: | 46 dB |
| Minimum Illumination: | 0.8 lx (0.08 footcandle) at F1.4 (C/L), 0.1 lx (0.01 footcandle) at F1.4 (B/W) |
| Gain Control: | ON (DNR-H), ON (DNR-L) or OFF (SET UP MENU) selectable |
| White Balance: | ATW1, ATW2 or AWC (SET UP MENU) selectable |
| Aperture: | Set Variable (SET UP MENU) |
| Electronic Light Control: | Equivalent to continuous variable shutter speeds between 1/60 s and 1/10 000 s |
| Super Dynamic II : | ON or OFF (SET UP MENU) selectable |
| Electronic Shutter Speed: | 1/60 (OFF), 1/100, 1/250, 1/500, 1/1 000, 1/2 000, 1/4 000, 1/10 000 s selectable |
| Lens Mount: | CS-mount (supplied with C-mount adapter) |
| ALC Lens: | DC or Video selectable |
| Ambient Operating Temperature: | -10 °C - +50 °C (14 °F - 122 °F) |
| Ambient Operating Humidity: | Less than 90 % |
| Power Source and Power Consumption: | 24 V AC 60 Hz, 4.3 W |
| Dimensions (without lens): | 67 mm (W) x 65 mm (H) x 72.5 mm (D) 2-5/8" (W) x 2-9/16" (H) x 2-7/8" (D) |
| Weights (without lens): | 0.33 kg (0.7 lbs.) |

Weights and dimensions indicated are approximate.
Specifications are subject to change without notice.

STANDARD ACCESSORIES

| | |
|---------------------------------------|-------|
| Body Cap..... | 1 pc. |
| ALC Lens Connector (YFE4191J100)..... | 1 pc. |
| C-mount Adapter | 1 pc. |

OPTIONAL ACCESSORIES

| | |
|----------|--|
| Lenses : | WV-LA2R8C3B, WV-LA4R5C3B, WV-LA9C3B, WV-LA210C3, WV-LA408C3 WV-LA908C3, WV-LZ61/10, WV-LZ61/15, WV-LZA61/2, WV-LZ62/2, WV-LZ62/8, WV-LF4R5C3A, WV-LF9C3A, WV-LZF61/2 |
|----------|--|

Panasonic Digital Communications & Security Company

Unit Company of Matsushita Electric Corporation of America
Security Systems
www.panasonic.com/cctv
Executive Office: One Panasonic Way 3E-7, Secaucus, New Jersey 07094
Zone Office
Eastern: One Panasonic Way, Secaucus, NJ 07094 (201) 348-7303
Central: 1707 N.Randal Road, Elgin, IL 60123 (847) 468-5205
Western: 6550 Katella Ave., Cypress, CA 90630 (714) 373-7840

PANASONIC CANADA INC.

5770 Ambler Drive, Mississauga, Ontario, L4W 2T3 Canada (905)624-5010

PANASONIC SALES COMPANY

DIVISION OF MATSUSHITA ELECTRIC OF PUERTO RICO INC.

San Gabriel Industrial Park 65th Infantry Ave. KM. 9.5 Carolina, P. R. 00985 (809)750-4300